

Cutlass Fasteners, Inc.

83 Vermont Ave., Unit 6, Warwick, RI 02888

Tel: (401) 732-6333 Fax: (401) 732-6336

cutlass-studwelding.com

Stud Welding...

- Fasteners
- Equipment
- Service

CLIPPER MANUAL

MODEL : CLIPPER 8 & 10/PKM MANUAL
PART NO. : CSS-3T/CSS-3B CSS-4T/CSS-4B
SERIAL NO. :



PLEASE READ THIS OPERATION AND MAINTENANCE MANUAL
CAREFULLY BEFORE USING YOUR NEW CUTLASS STUD WELDER.

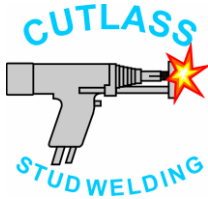

Cutlass Fasteners, Inc.

83 Vermont Ave., Unit 6, Warwick, RI 02888

Tel: (401) 732-6333 Fax: (401) 732-6336

cutlass-studwelding.com

Stud Welding...

- Fasteners
- Equipment
- Service

CLIPPER MANUAL

WARRANTY

The electrical and mechanical components of the Cutlass Stud Welders are thoroughly performance inspected prior to assembly in the Welder. The assembled Welder is completely performance checked. The Welder is delivered to you in perfect electro-mechanical condition. All parts used in the assembly of the Welder are fully warranted for a period of twelve (12) months from the date of delivery.

Under this warranty, the manufacturer reserves the right to repair or replace, at its option, defective parts which fail during the warranty period. Notice of any claim for warranty repair or replacement must be furnished to the manufacturer, by the purchaser, within five (5) days after the defect is first discovered. The manufacturer does not assume any liability for paying shipping costs, or for any labor or material furnished where such costs are not expressly authorized in writing.

We do not warrant the Cutlass Stud Welders, parts or accessories against failures resulting from misuse, abuse, improper installation, normal wear and tear, maladjustment or use not in accordance with the operating instructions furnished by the manufacturer. Cutlass shall never be liable for any consequential damages.

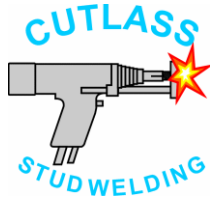

Cutlass Fasteners, Inc.

83 Vermont Ave., Unit 6, Warwick, RI 02888

Tel: (401) 732-6333 Fax: (401) 732-6336

cutlass-studwelding.com

Stud Welding...

- Fasteners
- Equipment
- Service

CLIPPER MANUAL

SUGGESTED SAFETY PRECAUTIONS

In any welding operation, it is the responsibility of the welder to observe certain safety rules to insure his personal safety and to protect those working near him.

Reference is directed without endorsement or recommendation, to ANSI Z49.1, Safety in Welding and Cutting, and to AWG Publication A6, 1-66 Recommended Safe Practices for Gas-Shielded Arc Welding.

1. Always treat electricity with respect. Under open circuit conditions, the welding machine output may be dangerous.
2. Do not work on live circuits and conductors. Disconnect the main power line before checking the machine or performing any maintenance operations.
3. Ensure the welding machine cabinet is properly grounded to a good electrical ground.
4. Do not stand in water or on damp floors while welding or weld in the rain. Avoid wearing wet or sweaty clothes when welding.
5. Do not operate with worn or poorly connected cables, and do not operate weld gun with loose cable connections. Inspect all cables frequently for insulation failures, exposed wires, loose connections and repair as needed.
6. Do not overload weld cables or continue to operate with hot cables.
7. Do not weld near flammable materials or liquids, in or near atmospheres, or on ducts carrying explosive gases.
8. Do not weld on containers which have held combustible or flammable materials, or on materials which give off flammable or toxic vapors when heated, without proper cleaning, purging, or inerting.
9. Ensure adequate ventilation is provided when welding in confined spaces.
10. Never look at the electrical arc without wearing eye shields.
11. Always use proper protective clothing, gloves etc. Never weld close to a bystander who is unaware of the possible dangers of ultraviolet light and weld splatter on their eyes.
12. Installation, servicing and trouble shooting should only be done by qualified personnel, familiar with this type of equipment.

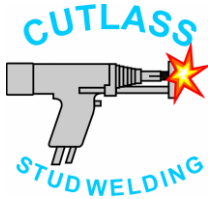

Cutlass Fasteners, Inc.

83 Vermont Ave., Unit 6, Warwick, RI 02888

Tel: (401) 732-6333 Fax: (401) 732-6336

cutlass-studwelding.com

Stud Welding...

- Fasteners
- Equipment
- Service

CLIPPER MANUAL

THE CAPACITOR DISCHARGE STUD WELDING PROCESS

HOW THE STUD WELD IS MADE:

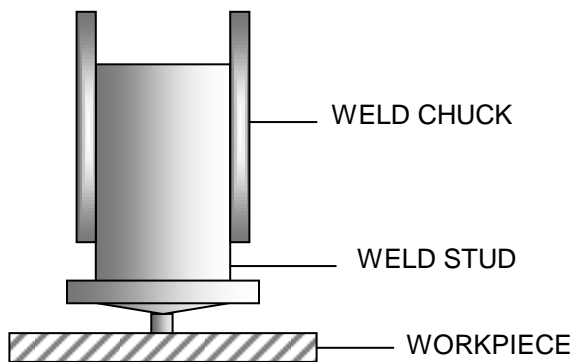

1. The stud is located on the spot to which it is to be welded.

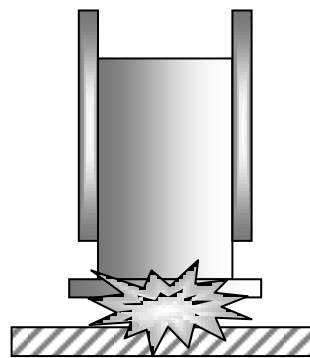

2. Stored energy is discharged through the precisely engineered weld tip at the base of the fastener.

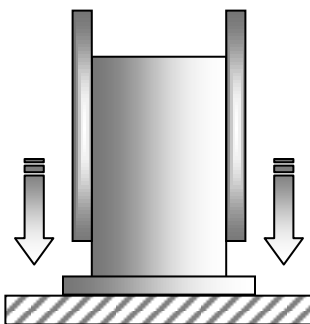

3. The stud is plunged into the molten weld pool, and fusion is achieved across the complete section of the weld.

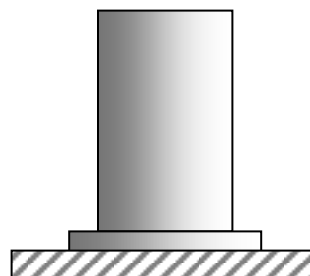

4. The weld gun is withdrawn leaving the fastener permanently welded to the workpiece.

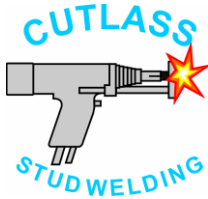

Cutlass Fasteners, Inc.

83 Vermont Ave., Unit 6, Warwick, RI 02888

Tel: (401) 732-6333 Fax: (401) 732-6336

cutlass-studwelding.com

Stud Welding...

- Fasteners
- Equipment
- Service

CLIPPER MANUAL

HOW TO INSTALL YOUR CUTLASS CLIPPER

1. Attach the ground cable to the workpiece with the "C" clamp. Connect the other end of the cable to the (+) Positive socket on the Clipper.
2. Connect the Control Plug (3 pin connector) on the Gun cable, to the 3 Pin Socket on the front of the Clipper.
3. Connect the Weld Cable Plug on the Gun cable to the (-) Negative socket on the front of the Clipper.
4. Connect the power lead to a 120 volt supply.

NOTE: UNIT IS SHIPPED FROM THE FACTORY TAPPED FOR 120 VOLT OPERATION. FOR 220/240 VOLT OPERATION THE TRANSFORMER MUST BE RE-TAPPED. SEE PAGE 12 FOR THE CORRECT PROCEDURE.

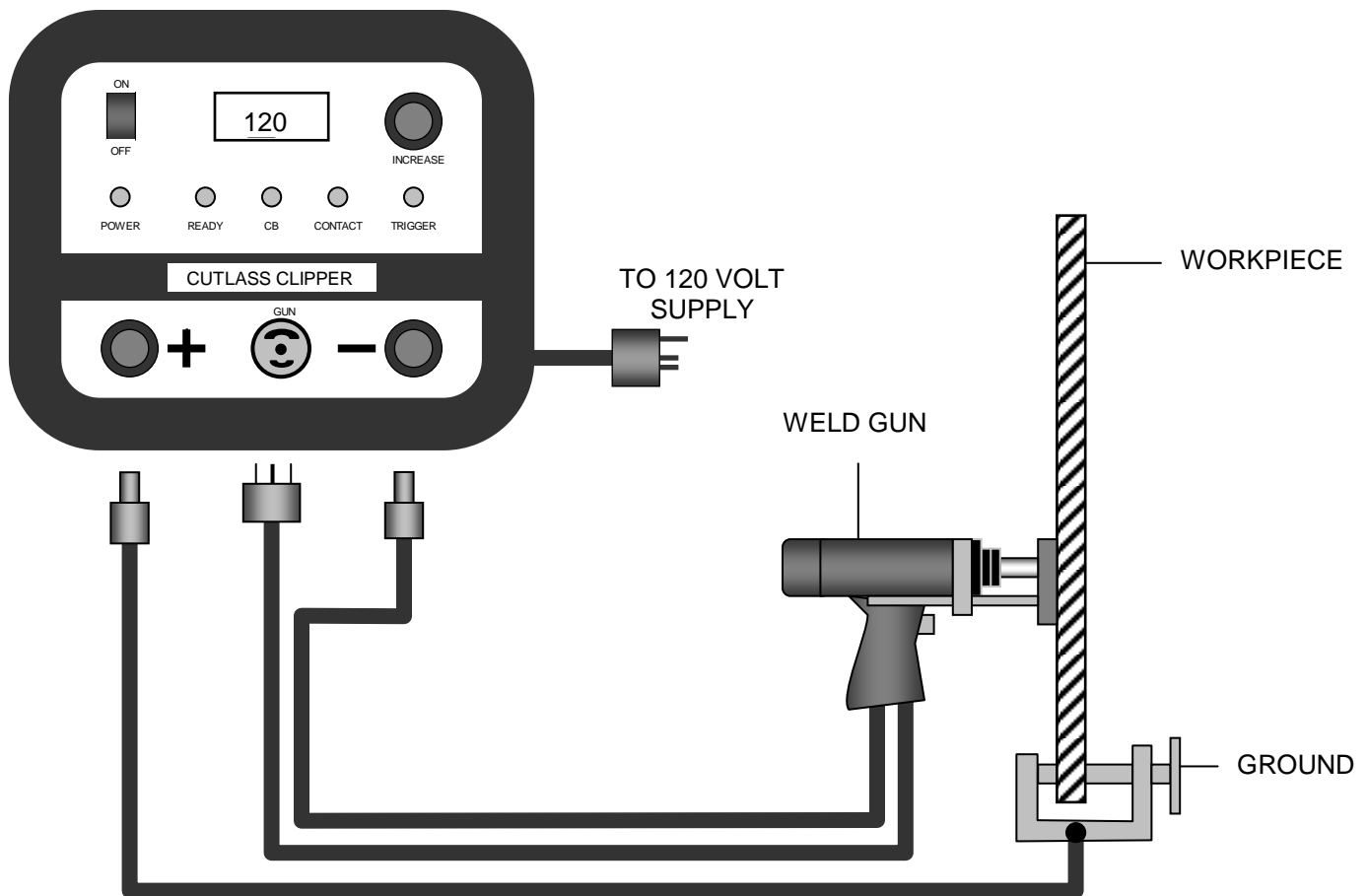

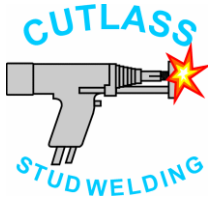

Cutlass Fasteners, Inc.

83 Vermont Ave., Unit 6, Warwick, RI 02888

Tel: (401) 732-6333 Fax: (401) 732-6336

cutlass-studwelding.com

Stud Welding...

- Fasteners
- Equipment
- Service

CLIPPER MANUAL

WELD GUN SETUP

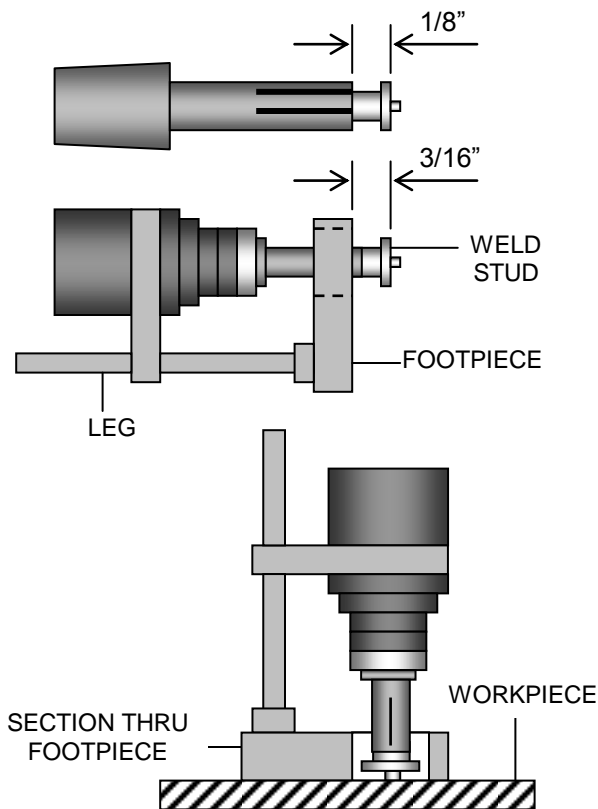

1. The weld chuck should be adjusted as shown. For longer studs, as much of the stud should be held as possible. This may require complete removal of the adjusting screw.
2. Seat weld chuck firmly in the front of weld gun and attach leg and footpiece assembly. Set leg depth so approximately 3/16" of stud/chuck protrudes beyond the footpiece.
3. Place the weld gun perpendicular to the workpiece as shown. Apply pressure to the gun so the footpiece lies firmly on the workpiece.
4. Hold gun steady and pull trigger when stud is in required position. After weld cycle withdraw gun from stud. Pull gun straight back so weld chuck is not damaged.
5. Inspect weld and adjust setting as required.

TEST WELDING

Before making your first weld, check the ground clamp. It is essential that no power be lost through a poor connection. The surface under the ground should be free from oil, scale, grease and rust. The test should be on a piece of scrap material similar to the material to be used during actual production.

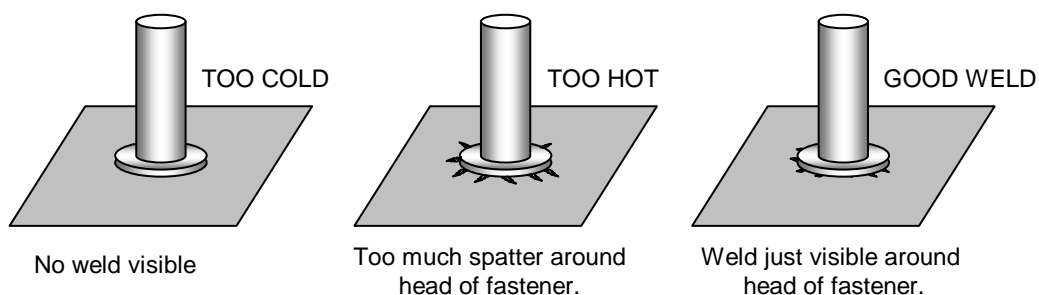

NOTE: IF WELD APPEARS COLD, DO NOT PLACE GUN ON WELDED STUD AND TRIGGER AGAIN. DAMAGE TO WELD CHUCK OR CONTROLLER WILL OCCUR.

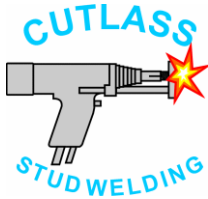

Cutlass Fasteners, Inc.

83 Vermont Ave., Unit 6, Warwick, RI 02888

Tel: (401) 732-6333 Fax: (401) 732-6336

cutlass-studwelding.com

Stud Welding...

- Fasteners
- Equipment
- Service

CLIPPER MANUAL

The electrical and mechanical parameters of the weld are set using the voltage control knob on the front of the welder and by adjusting the spring pressure of the welding gun.

ADJUSTING THE PKM-1B WELD GUN

The welding time depends on the speed of the stud as it moves forward into the molten welding pool. The speed is adjusted directly by changing the spring pressure. The greater the spring pressure, the shorter the welding time.

To adjust, use a coin or broad bladed screw driver to turn the adjusting knob in the center of the back cap: Clockwise to increase spring pressure and Counterclockwise to reduce spring pressure. Set the spring pressure by observing the pointer in the window on the side of the weld gun. Re-tighten the small screw in the back cap.

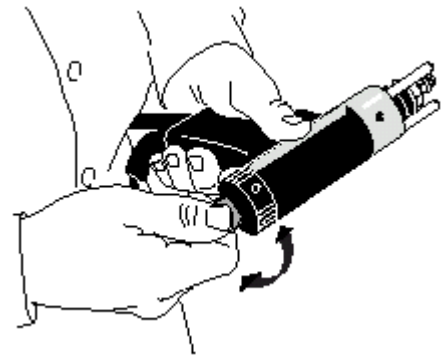

Exploded view of window scale on side of weld gun.

The gun is shipped from the factory in the 1-2 position. The suggested spring settings are shown below...

WORKPIECE MATERIAL	STUD MATERIAL AND DIAMETER														
	MILD STEEL					STAINLESS STEEL					ALUMINUM ALLOY				
	#6	#8	#10	1/4	5/16	#6	#8	#10	1/4	5/16	#6	#8	#10	1/4	5/16
STEEL	1-2	1-2	1-2	1-2	1-2	1-2	1-2	1-2	1-2	1-2	-	-	-	-	-
STEEL GALVANIZED	1-2	1-2	1-2	1-2	-	1-2	1-2	1-2	1-2	1-2	-	-	-	-	-
STAINLESS STEEL	1-3	1-3	1-3	1-3	1-3	1-3	1-3	1-3	1-3	1-3	-	-	-	-	-
ALUMINUM ALLOY	-	-	-	-	-	-	-	-	-	-	4-6*	4-6*	4-6*	4-6*	-

* Aluminum studs can be welded using the contact method with limitations

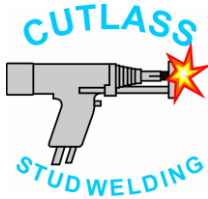

Cutlass Fasteners, Inc.

83 Vermont Ave., Unit 6, Warwick, RI 02888

Tel: (401) 732-6333 Fax: (401) 732-6336

cutlass-studwelding.com

Stud Welding...

- Fasteners
- Equipment
- Service

CLIPPER MANUAL

VOLTAGE CONTROL

A variable voltage control knob is mounted on the front panel of the unit. Before turning the power switch on, the voltage knob should be turned to the fully counter-clockwise position.

When the equipment is completely connected, turn the power switch to the "ON" position. The red power light will glow indicating power is supplied to the machine. Slowly turn the voltage control knob clockwise to increase power and set according to the recommendations below. To adjust the voltage down it is necessary to turn the unit off for several seconds, turn the voltage control knob counter-clockwise, turn the power on again, and increase voltage to the required setting.

The settings shown below are to be used as a guide only, and we recommend test welding on scrap material to ascertain optimum weld parameters for a specific application.

STUD MATERIAL	STUD SIZE	VOLTAGE SETTING		
		CLIPPER 6	CLIPPER 8	CLIPPER 10
MILD STEEL & STAINLESS	#6 (3mm)	120-130	80-95	70-80
	#8 (4mm)	140-150	95-110	75-90
	#10 (5mm)	140-150	95-110	75-90
	1/4 (6mm)	165-180	145-160	110-125
	5/16 (8mm)	*****	165-180	130-145
	3/8 (10mm)	*****	*****	160-180
ALUMINUM & BRASS	#6 (3mm)	130-145	95-120	80-90
	#8 (4mm)	165-180	140-155	90-115
	#10 (5mm)	165-180	140-155	90-115
	1/4 (6mm)	*****	165-180	135-150

**The settings shown above are for standard Flanged welding studs. For Mini-Flanged or Non-Flanged Studs, lower settings will be required.

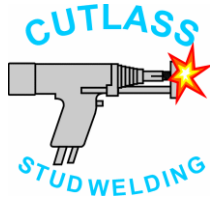

Cutlass Fasteners, Inc.

83 Vermont Ave., Unit 6, Warwick, RI 02888

Tel: (401) 732-6333 Fax: (401) 732-6336

cutlass-studwelding.com

Stud Welding...

- Fasteners
- Equipment
- Service

CLIPPER MANUAL

CAUSES OF POOR OR ERRATIC WELDS

1. Loose weld chuck – does not grip stud tightly.
2. Faulty or loose ground connections.
3. Dirty base material (oil, grease, rust etc).
4. Voltage too high or too low.
5. Broken or loose cables.
6. Gun binding – dirt in weld gun preventing free movement.
7. Leg and/or footpiece incorrectly set.
8. Use of center punch.
9. Weld cables coiled.

NOTE: The weld cables and ground cables should be laid out in a straight line or large loops. Poor weld quality may result if welding cables are closely coiled.

WELDER MAINTENANCE

Your Cutlass welder is designed for long service with minimum care. Ordinary common sense maintenance will keep it operating efficiently. Following are some tips on preventative maintenance:

1. Treat the welding and control cables with respect. Avoid sharp bends and kinks which may break the cables. Do not use the cables as a "tow-line" to move controller. Avoid damaging or straining the cables where they enter the gun or connectors.
2. Ensure unit vents are not obstructed, and that the unit is not covered while in use. Avoid overheating.
3. Keep the welding gun free of dust and dirt. Periodically clean weld splatter from front of gun.
4. The welder should not be placed in close proximity to any MIG or TIG welders, nor should the Clipper share a common power supply with MIG or TIG equipment. Similarly the main ground connection from the Clipper to the workpiece should not be linked in any way to MIG or TIG grounds.

FAILURE TO COMPLY COULD INVALIDATE YOUR WARRANTY

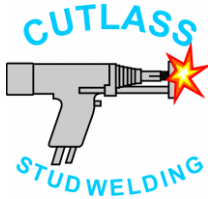

Cutlass Fasteners, Inc.

83 Vermont Ave., Unit 6, Warwick, RI 02888

Tel: (401) 732-6333 Fax: (401) 732-6336

cutlass-studwelding.com

Stud Welding...

- Fasteners
- Equipment
- Service

CLIPPER MANUAL

STANDARD ACCESSORIES

INCH

STUD SIZE	PART NUMBER
2-56UNC	015-509
12GA, 4-40UNC	602-467A
1/8	015-511
10GA, 6-32UNC	602-451A
8-32UNC	602-452A
#10, 3/16	605-101A
0.217	605-112
1/4	605-104A
5/16	605-105A
3/8	605-106A

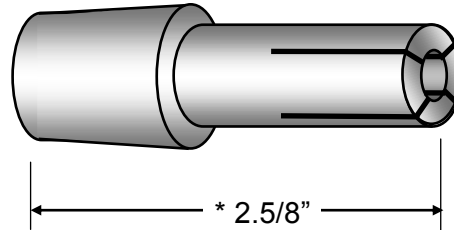

STANDARD ADJUSTABLE WELD CHUCKS

METRIC

STUD SIZE	PART NUMBER
3MM	605-111
4MM	602-423A
5MM	605-102
6MM	605-103
8MM	605-105A
10MM	605-106

- LONGER LENGTHS AVAILABLE ON REQUEST

CD FOOTPIECE

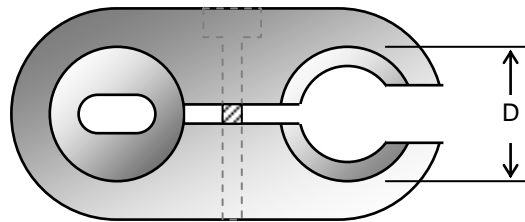

SIZE	'D' DIA.	PART NO.
SMALL	7/8"	023-252
MEDIUM	1.160"	023-252M

DESCRIPTION	PART NO.
JIG LOCATING BUSH D = 7/8"	650-691
NAIL GUIDE D = 7/8"	601-350
CHUCK DRIFT	000-374
SPARK SHIELD, SML. D = 1.16", A = 3/16"	999-013
SPARK SHIELD, LGE. D = 1.16", A = 1/2"	999-018

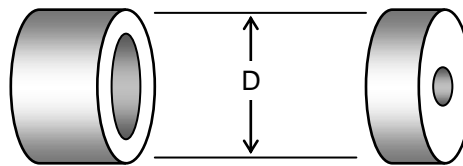

JIG LOCATING BUSH

NAIL GUIDE



CHUCK DRIFT

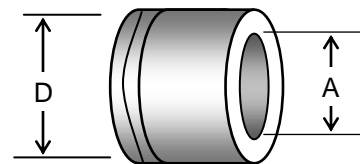

SPARK SHIELD

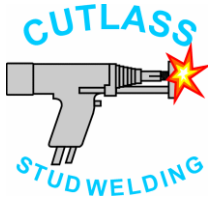

Cutlass Fasteners, Inc.

83 Vermont Ave., Unit 6, Warwick, RI 02888

Tel: (401) 732-6333 Fax: (401) 732-6336

cutlass-studwelding.com

Stud Welding...

- Fasteners
- Equipment
- Service

CLIPPER MANUAL

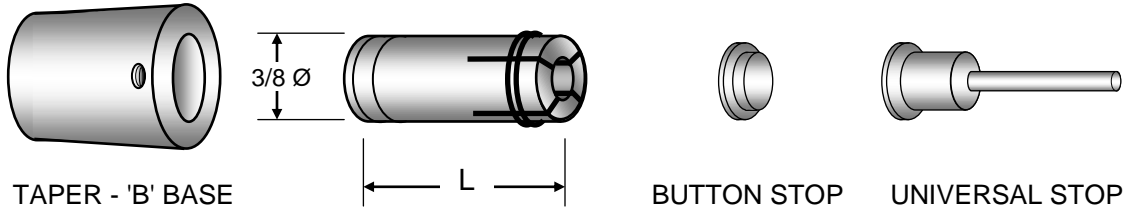

TAPER - 'B' BASE

BUTTON STOP

UNIVERSAL STOP

INCH SIZES

STUD SIZE	"L" LENGTH	PART NUMBER
2-56UNC	1.3/8"	669-232
12GA., 4-40UNC	1.3/8"	669-219
1/8	1.3/8"	669-230
10GA., 6-32 UNC	1.3/8"	669-220
8-32 UNC	1.3/8"	669-222
3/16, 10-24UNC, 10-32UNF	1.3/8"	669-216
0.217	1.3/8"	669-217
1/4	1.3/8"	669-218
5/16	1.3/8"	669-228
3/8	1.3/8"	669-229

METRIC SIZES

STUD SIZE	"L" LENGTH	PART NUMBER
3MM	1.3/8"	669-243
4MM	1.3/8"	669-231
5MM	1.3/8"	669-244
6MM	1.3/8"	669-235
8MM	1.3/8"	669-228
10MM	1.3/8"	669-247

ACCESSORIES

ITEM	PART NUMBER
B COLLET TAPER BASE	669-223
BUTTON STOP	669-225A
UNIVERSAL STOP	669-225

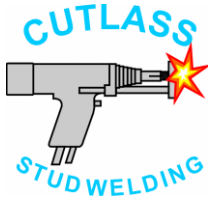

Cutlass Fasteners, Inc.

83 Vermont Ave., Unit 6, Warwick, RI 02888

Tel: (401) 732-6333 Fax: (401) 732-6336

cutlass-studwelding.com

Stud Welding...

- Fasteners
- Equipment
- Service

CLIPPER MANUAL

PKM-1B GUN PARTS

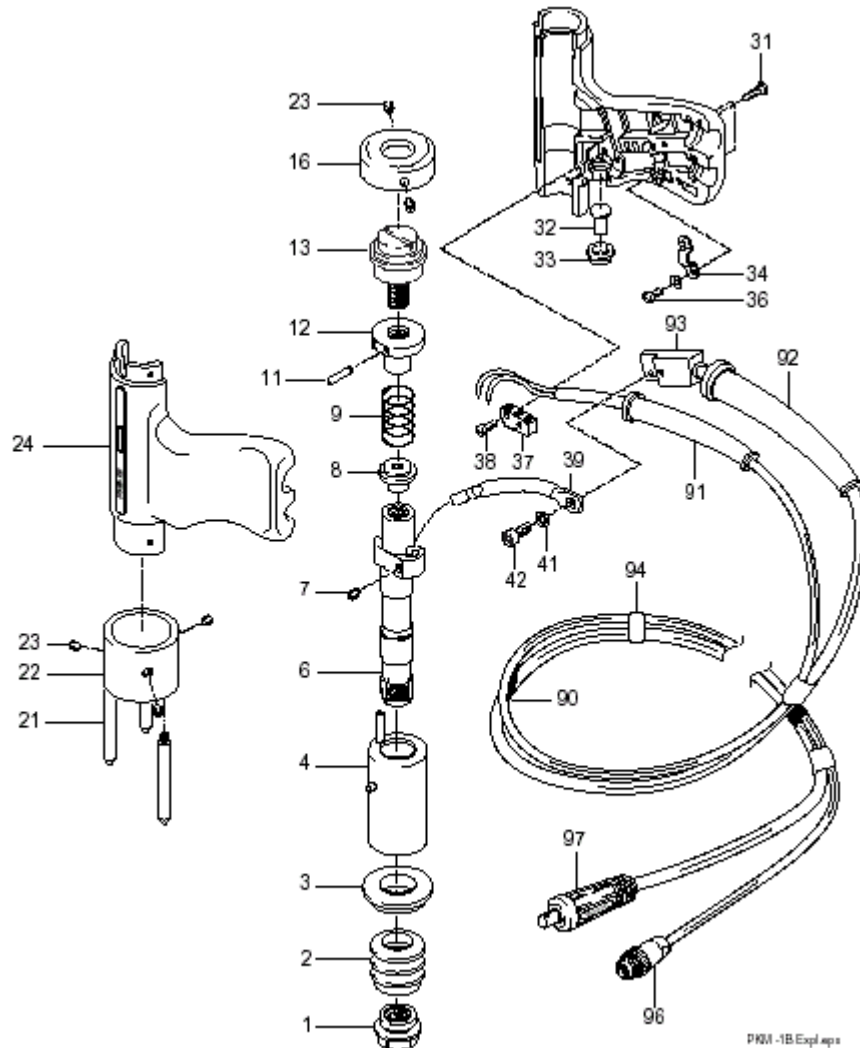

ALTERNATE PARTS...

ITEM	PART NO.	DESCRIPTION	QTY
1A	80-40-1741	B COLLET ADAPTOR	1
22A	80-40-1739	SINGLE LEG FACEPLATE	1
22B	80-40-1113	TWIN LEG FACEPLATE	1

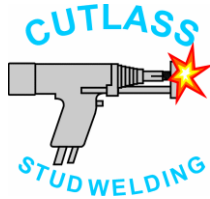

Cutlass Fasteners, Inc.

83 Vermont Ave., Unit 6, Warwick, RI 02888

Tel: (401) 732-6333 Fax: (401) 732-6336

cutlass-studwelding.com

Stud Welding...

- Fasteners
- Equipment
- Service

CLIPPER MANUAL

PKM-1B GUN PARTS

ITEM	PART NO.	DESCRIPTION	QTY
	90-10-2126	COMPLETE WELD GUN	1
1	80-40-1738	TAPER CHUCK ADAPTOR	1
2	80-40-1097	BELLOWS	1
3	80-40-1023	INSULATING BUSH	1
4	80-40-1020	GUIDE BUSH	1
6	80-40-1740	SPINDLE	1
7	80-15-1011	M5 X 8 SOC. HD. SCREW	1
8	80-40-1027	SPRING PLATE	1
9	80-40-1031	MAIN SPRING	1
11	80-15-1022	M3 X 12 SOC. HD. SCREW	1
12	80-40-1015	ADJUSTING NUT	1
13	80-40-1603	SPRING ADJUSTING SCREW	1
16	80-40-1028	BACK CAP	1
21	80-40-1012	TRIPOD LEG	3
22	80-40-1013	TRIPOD FACEPLATE	1
23	80-15-1010	M5 X 4 SOC. HD. SCREW	1
24	80-40-1602	GUN BODY (TOP & BOTTOM)	1
31	80-10-1013	HANDLE SCREW	3
32	80-40-1016	TRIGGER BUTTON	1
33	80-40-1017	TRIGGER SLEEVE	1
34	80-10-1015	CABLE CLIP	1
36	80-15-1061	M2.5 X 8 SCREW	2
37	80-50-1013	TRIGGER SWITCH	1
38	80-15-1015	M2.0 X 10	2
39	80-72-1012	INTERNAL WELD CABLE	1
41	80-15-1016	M4 LOCK WASHER	1
42	80-15-1012	M4 X 8 SOC. HD. CAP SCREW 1	1
90	80-72-1039	WELD/CONTROL CABLE (16FT.)	1
91	80-10-1011	CONTROL CABLE SLEEVE	1
92	80-10-1013	WELD CABLE SLEEVE	1
93	80-35-1134	CABLE CONNECTING BLOCK	1
94	600-627	CABLE SLEEVE	1
96	000-594P	CONTROL PLUG C/M	1
97	000-568	WELD PLUG C/M	1

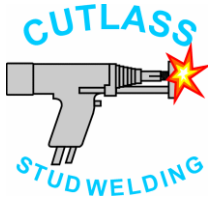

Cutlass Fasteners, Inc.

83 Vermont Ave., Unit 6, Warwick, RI 02888

Tel: (401) 732-6333 Fax: (401) 732-6336

cutlass-studwelding.com

Stud Welding...

- Fasteners
- Equipment
- Service

CLIPPER MANUAL

CLIPPER 8 PARTS LIST

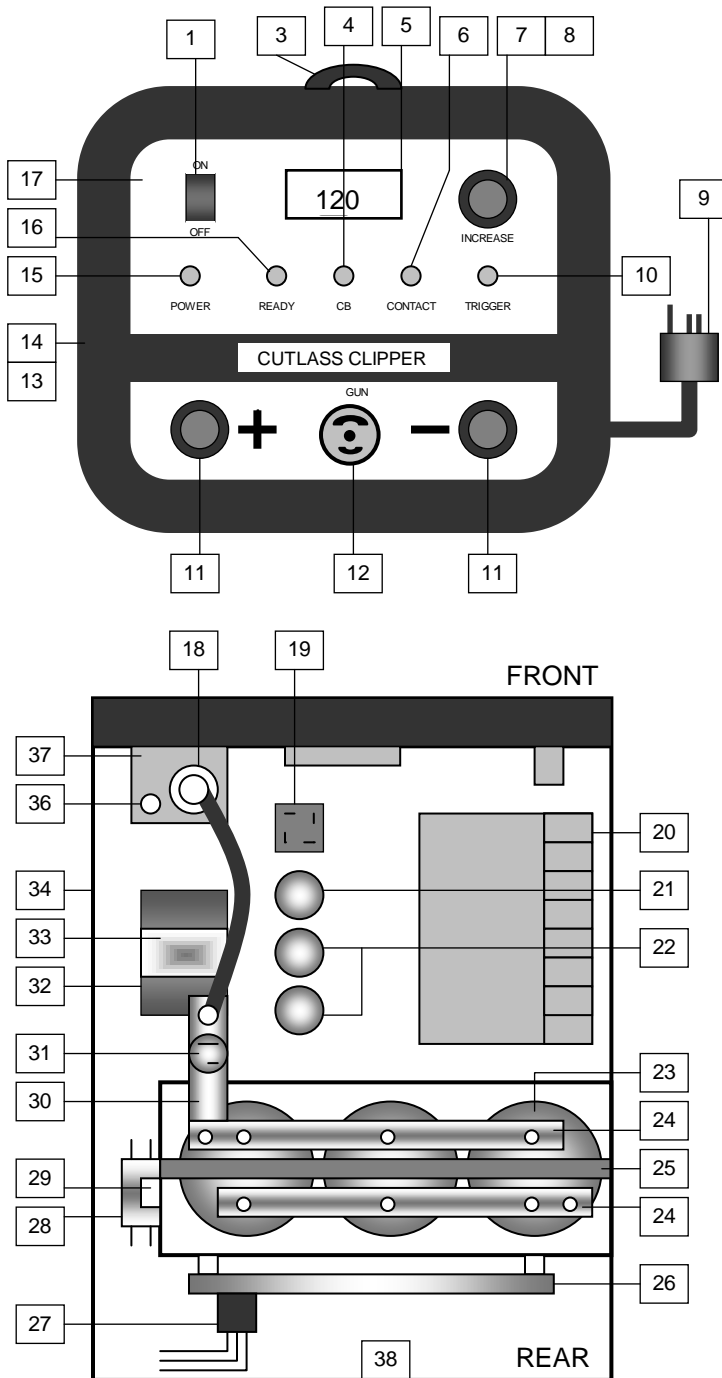

ITEM	DESCRIPTION	PART NO.
1	ON/OFF SWITCH	018-862
3	CARRYING HANDLE	602-1163
4	CIRCUIT BREAKER	999-071
5	VOLTMETER	999-110
6	CONTACT LIGHT	602-1196
7	POTENTIOMETER	001-031
8	POTENTIOMETER KNOB	600-657
9	POWER CABLE	999-090
10	TRIGGER LIGHT	602-1196
11	WELD SOCKET P/M	000-577
12	CONTROL SOCKET P/M	000-598P
13	OUTER COVER	901-046
14	PANEL TRIM	602-318A
15	POWER LIGHT	602-1194
16	READY LIGHT	602-1195
17	FRONT FACIA DECAL	602-318A
18	WELD SCR	602-212
19	BRIDGE RECTIFIER	019-592
20	MAIN TRANSFORMER	602-1268
21	DISCHARGE RESISTOR	002-984
22	CHARGE RESISTOR	011-494
23	CAPACITOR 22,000MFD	602-2299
24	STANDARD BUSS BAR	018-838
25	CAPACITOR CLAMP	602-1869
26	PC BOARD	602-1212
27	WIRE HARNESS	602-1213
28	MAINS FILTER	602-1065
29	WIRE CLIP	602-1272
30	NEGATIVE BUSS BAR	602-1899
31	CHARGE SCR	003-461
32	RELAY BASE	602-250
33	RELAY 120VOLT	602-249
34	CHASSIS	901-047
36	INSULATOR STANDOFF	901-064
37	HEATSINK PLATE	602-1187
38	REAR PANEL	901-045

* SEE NEXT PAGE FOR CLIPPER "10" PARTS.

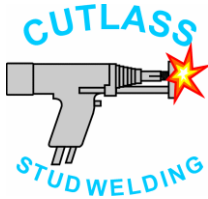

Cutlass Fasteners, Inc.

83 Vermont Ave., Unit 6, Warwick, RI 02888

Tel: (401) 732-6333 Fax: (401) 732-6336

cutlass-studwelding.com

Stud Welding...

- Fasteners
- Equipment
- Service

CLIPPER MANUAL

CLIPPER 10 PARTS LIST

All parts used are the same as the Clipper 6 and 8 except the following:

PKM-1B WELD GUN

ITEM	DESCRIPTION	PART NO.
27	#2 WELD CABLE	602-078

CLIPPER 10 CONTROLLER

ITEM	DESCRIPTION	PART NO.
13	OUTER COVER	901-048
30	NEGATIVE BUSS BAR	602-1904
34	CHASSIS	901-047
39*	POSITIVE BUSS BAR	602-1496

* NOT SHOWN

TRANSFORMER TAPPING...ALL MODELS

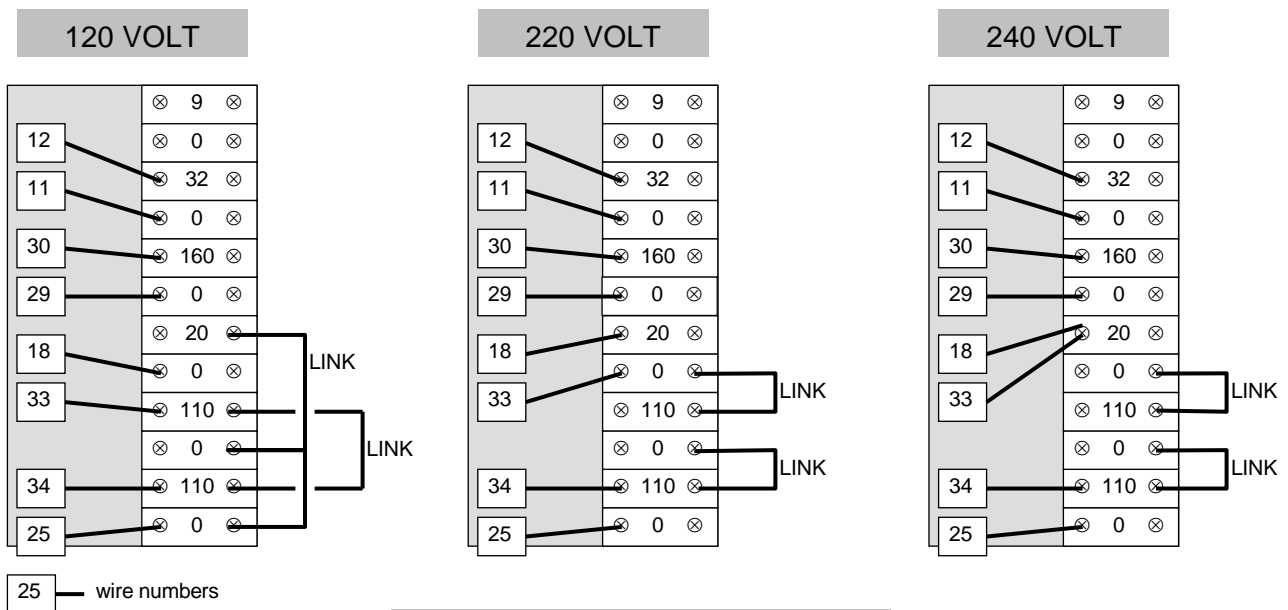

MAIN TRANSFORMER...TOP VIEW

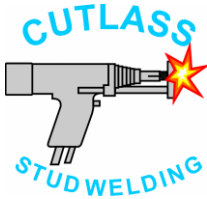

Cutlass Fasteners, Inc.

83 Vermont Ave., Unit 6, Warwick, RI 02888

Tel: (401) 732-6333 Fax: (401) 732-6336

cutlass-studwelding.com

Stud Welding...

- Fasteners
- Equipment
- Service

CLIPPER MANUAL

